



PADUNGSILPA ENGINEERING CO.,LTD.

ALL YOU NEED IN TANKS

Tel : (662) 593-1109-10 Fax : (662) 593-1112

5.2 Φ977-100 sealed and locked inspection manhole cover & frame

Product Name :Φ977-100 Sealed and Locked inspection manhole cover & frame

Product Specification :Φ1080X100mm

Code :D400 Enforcement Standard: EN124: 1994

Color: Black

Product Structure: cover, frame, inspection sub-cap, seals and locks

Composition of product material: manhole cover, I frame, inspection sub-cap consists of SMC composite material, seals and locks consist of 304 stainless steel fastener and corrosion resistant rubber

Operating temperature range : -40°C~100°C

Application Field: Used for frequent road and ground for heavy vehicles such as freight terminal and wharf



Product structure diagram and specification dimensions

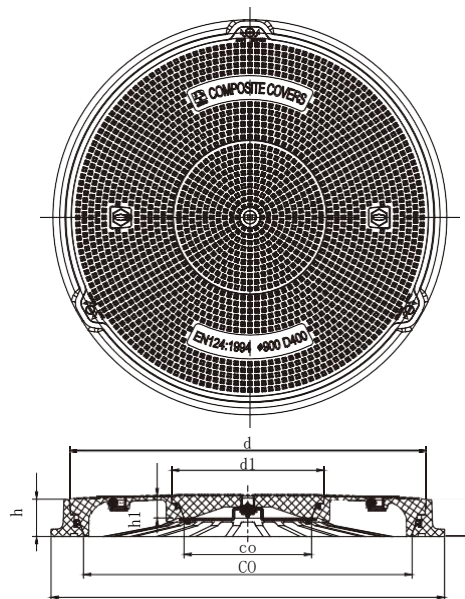

Resist load = 40 tons

Cover	Load Rating	Cover Dimension	Depth of Insertion(h)	Cover Diameter (d)	Weight
	D400	Φ1008×115	100 mm	Φ980mm	50Kg
Central Cover	Central Cover Dimension	Depth of Insertion(h ₁)	Cover Diameter d ₁	Central Cover Clean Opening (co)	Weight
	Φ420×60	60 mm	Φ420mm	350 mm	10.5Kg
Frame	Frame Dimension	Frame Depth(H)	Frame Outer Diameter (D)	Net Opening (CO)	Weight
	Φ1080×100	100 mm	Φ1080mm	900 mm	21Kg

TYPICAL INSTALLATION COMPOSITE MANHOLE COVER

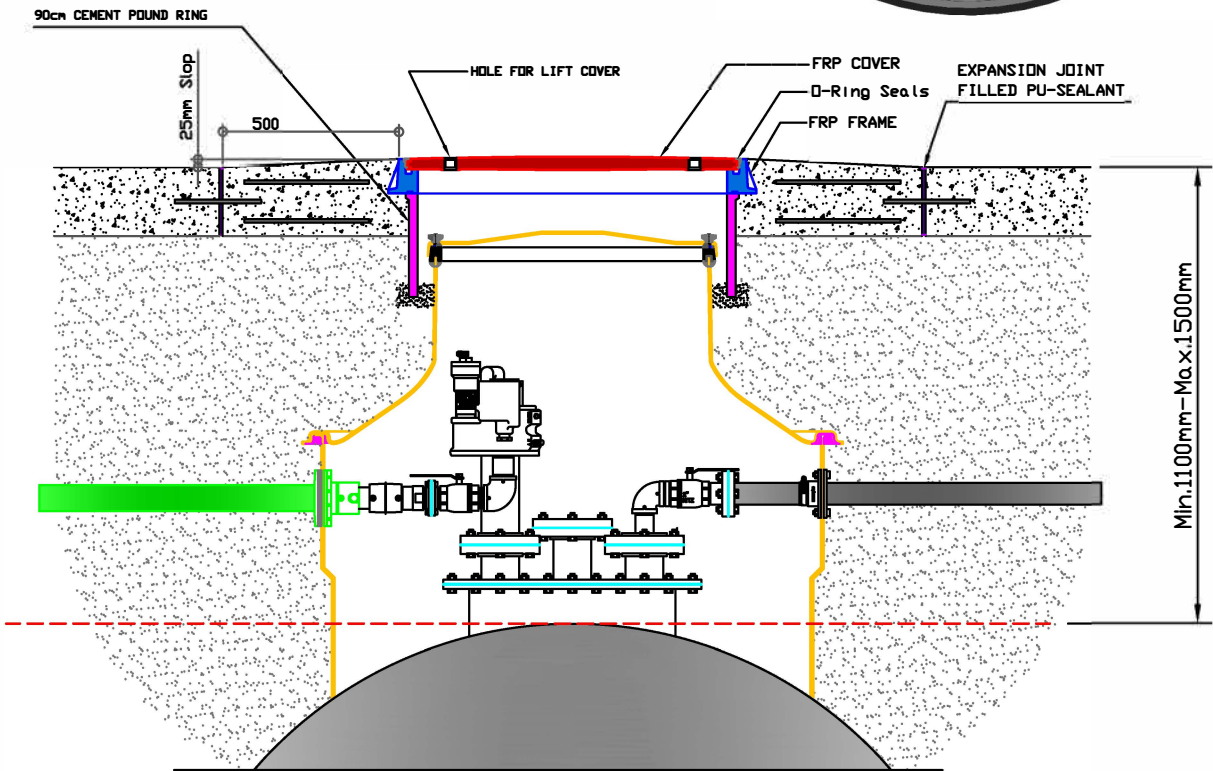
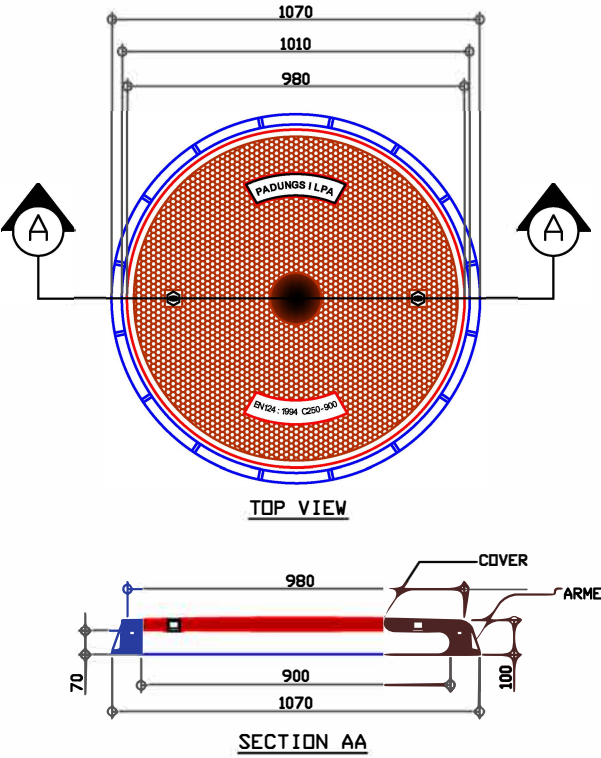

Specification : C250 Ø900 PSE-SMC Composite manhole cover

Product material composition: SMC Composite
 Dimension : Ø 980 x 1070mm
 Net Opening : Ø 900mm
 Code : C250 (25 Ton)
 Executive Standard : EN124:1994
 Product Color : Black
 Weight Cover : 49 Kg
 Weight Frame : 19 Kg

OPERATING INSTRUCTIONS:

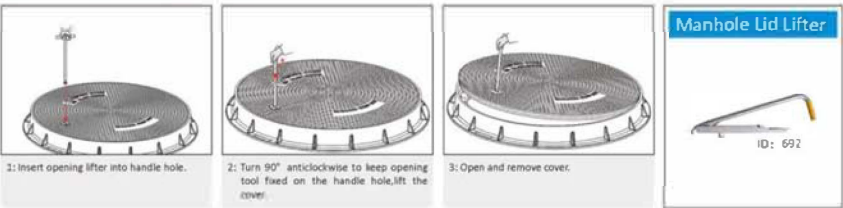

	PADUNGSILPA ENGINEERING CO.,LTD. 16/77 Soi, CHANGWATTANA14 , CHANGWATTANA14 RD. THUNG SONG HENG , LAKSI , BANGKOK 10210 THAILAND. Tel. 02-573-3533 , 02-573-4222 Fax. 02-573-7786	
	PSE- 900mm/25T COMPOSITE MAMHOLE COVER (WATER PROOF)	DRN Ch. Channan CKD Sheet 1 Of 1
PROJECT	DATE 23-07-2021	
DRG TITLE	REV	0