



PADUNGSILPA ENGINEERING CO.,LTD.

ALL YOU NEED IN TANKS

Tel : (662) 593-1109-10 Fax : (662) 593-1112

Φ977-100 Manhole Cover & Frame

Product Name :

Φ977-100 manhole cover & frame

Specification :

Φ1074×100mm

Code : C250 D400

Executive Standard:

EN124: 1994

Product Color: Black

Product structure: Well cover, well frame, detachable side sealed structure

Product material composition: manhole cover, well frame is composed

of SMC composite, side seal structure is composed of SMC

composite ,304 stainless steel fastener and corrosion resistant rubber

Operating temperature range :-40°C~100°C

Product Application:

C250 used for motor vehicle driving roads and parking areas

D400 used for freight stations, docks and other heavy vehicles

frequently driving roads, venues

Product structure diagram and specification dimensions

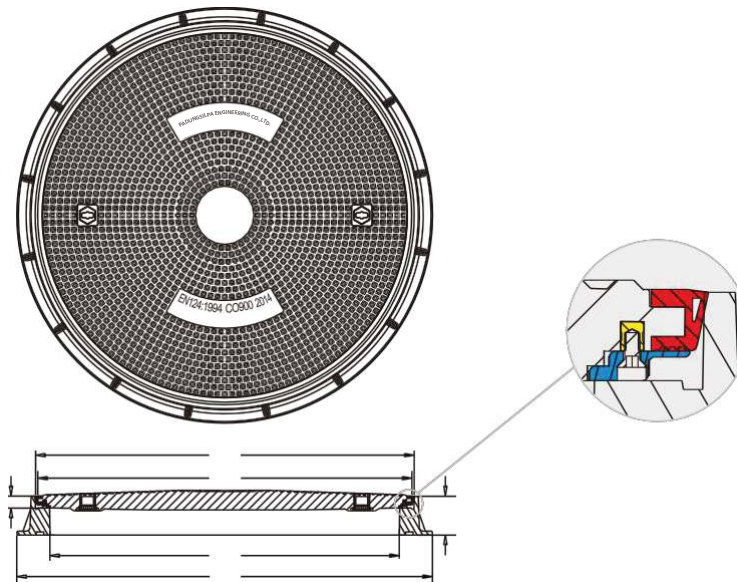

Cover	Load Rating	Cover Dimension	Depth of Insertion(h)	Cover Diameter (d1)	Cover Diameter (d2)	Weight
	C250	Φ977×55mm	30 mm	Φ977mm	Φ966mm	49Kg
D400	Φ977×55mm	30 mm	Φ977mm	Φ966mm	49Kg	

Frame	Cover Dimension	Frame Depth(H)	Frame Outer Diameter(D)	Net Opening (CO)	Weight
	Φ1074×100mm	100 mm	Φ1074mm	900 mm	19Kg

TYPICAL INSTALLATION COMPOSITE MANHOLE COVER

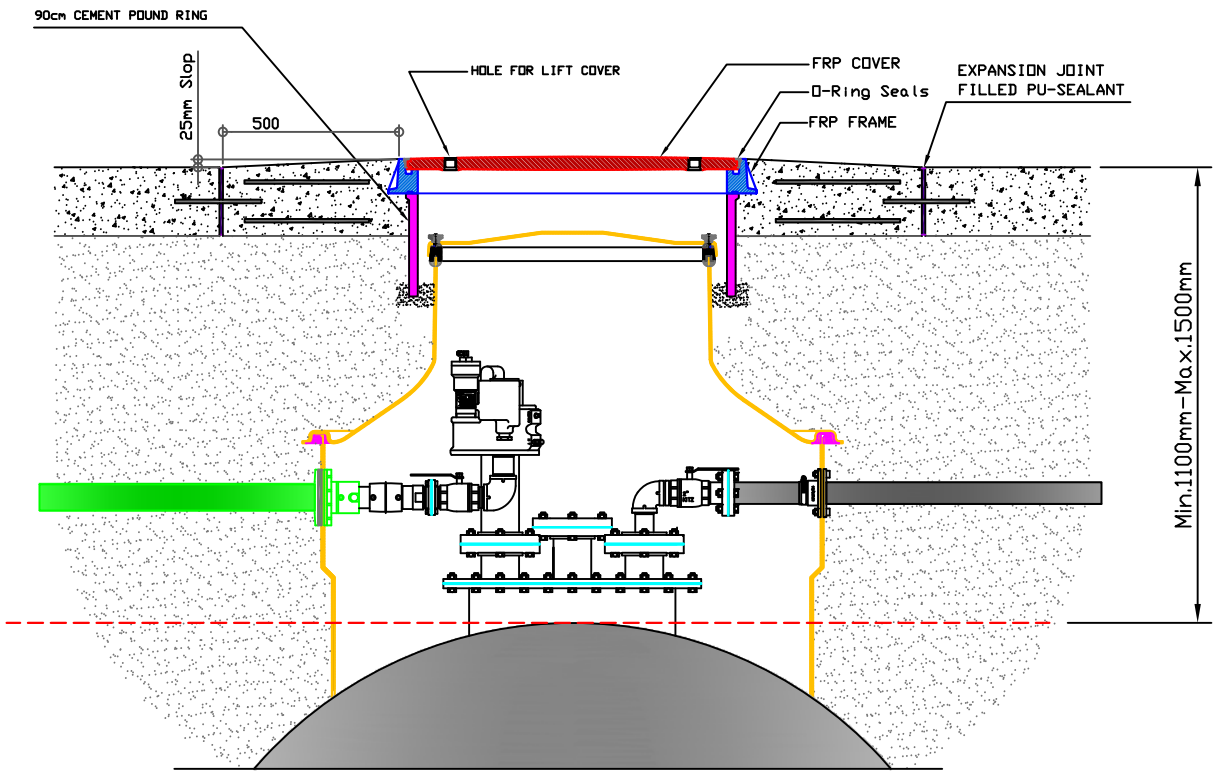
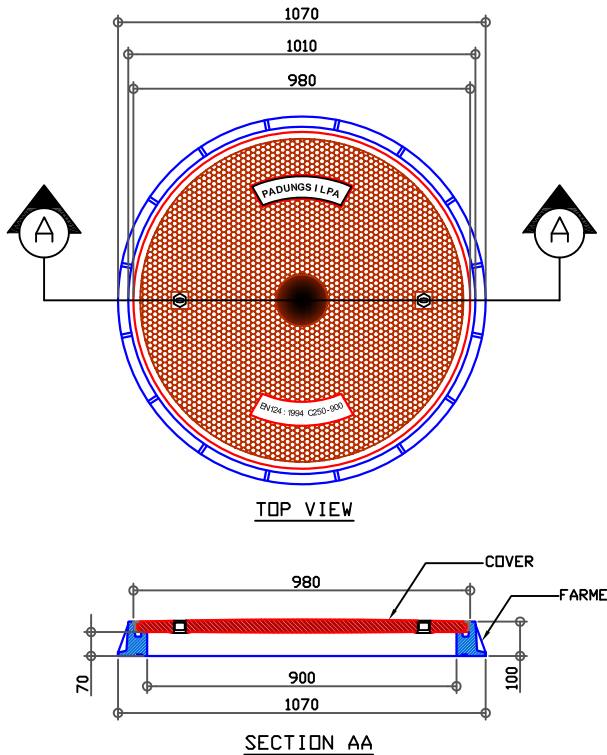

Specification : C250 \varnothing 900 PSE-SMC Composite manhole cover

Product material composition: SMC Composite
 Dimension : \varnothing 980 x 1070mm
 Net Opening : \varnothing 900mm
 Code : C250 (25 Ton)
 Executive Standard : EN124:1994
 Product Color : Black
 Weight Cover : 49 Kg
 Weight Frame : 19 Kg

OPERATING INSTRUCTIONS:

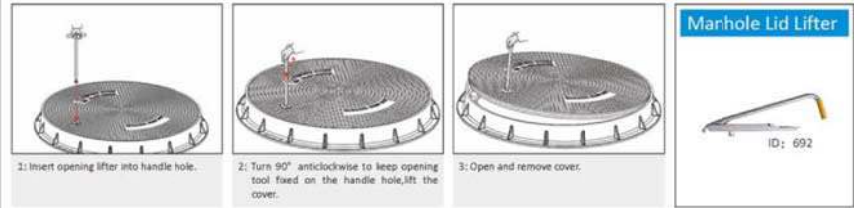

	PADUNGSILPA ENGINEERING CO.,LTD. 16/77 Soi, CHANGWATTANA14, CHANGWATTANA14 RD. THUNG SONG HONG, LAKSI, BANGKOK 10210 THAILAND. Tel. 02-573-3533, 02-573-4222 Fax. 02-573-7726	
	PSE- 900mm/25T COMPOSITE MAMHOLE COVER (WATER PROOF)	DRN Ch. Chamman CKD Sheet 1 Of 1
PROJECT	DATE 23-07-2021	
DRG TITLE.	REV 0	